

Infinity C233W

User Manual Version #2: Camera with ICON Menu

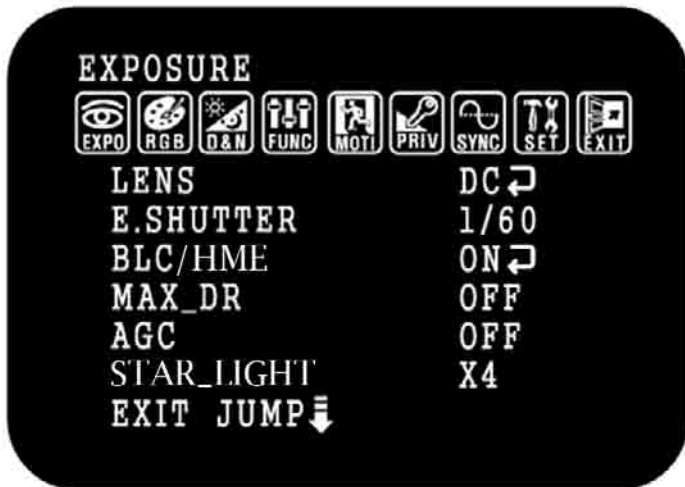

PRECAUTIONS

- Do not open or modify.
- Do not open the case except during maintenance and installation, for it may be dangerous and can cause damages.
- Do not put objects into the unit.
- Keep metal objects and flammable substances from entering the camera. It can cause fire, short-circuits, or other damages.
- Be careful when handling the unit.
- To prevent damages, do not drop the camera or subject it to shock or vibration.
- Do not install near electric or magnetic fields.
- Protect from humidity and dust.
- Protect from high temperature.
- Be careful when installing near the ceiling of a kitchen or a boiler room, as the temperature may rise to high levels.
- Cleaning
- To remove dirt from the case, moisten a soft cloth with a soft detergent solution and wipe.
- Mounting Surface
- The material of the mounting surface must be strong enough to support the camera.

FCC COMPLIANCE

This equipment has been tested and found to comply with the limits for a Class B digital device, pursuant to Part 15 of the **FCC** rules. These limits are designed to provide reasonable protection against harmful interference when the equipment is operated in a residential environment. This equipment generates, uses, and radiates radio frequency energy; and if it is not installed and used in accordance with the instruction manual, it may cause harmful interference to radio communications.

WARNING: Changes or modifications are not expressly approved by the manufacture.

TROUBLESHOOTING

Before sending your camera for repair, check the following or contact our technical specialist.

No VIDEO

- Check the coaxial cable and make sure it is connected securely.
- Check the lens' iris adjustment at the menu setup of the camera.
- Check the power supply and make sure the camera has the proper voltage and current.

Out-of-Focus VIDEO

- Check the clear dome cover and the lens for dirt or fingerprints. Use a soft cloth and gently clean.
- Check the lens manual focal and zoom adjustment. Field test monitor is recommended.

FEATURES

- 1/3" Sony Super HAD II CCD
- High Resolution 560 TV Lines
- True Day & Night / TDN5 (Electro Magnetic Mechanism)
- Star-Light (Super Low Light Technology)
- Max-DR (Electronic Wide Dynamic Range)
Enables the camera to capture perfect images in both bright and dark environments simultaneously.
- 3D-DNR (3D Digital Noise Reduction)
Produces less noise and more color during low-light application.
- HME (Highlight Mask Exposure)
Masks overly exposed light to produce a true video image of any environment.
- SLC (Side Light Compensation)
- DIS (Digital Image Stabilizer)
- Programmable Privacy Zone (6) & Motion Detection
- Easy Icon Driven OSD Menu with Built-In Joystick
- Negative Imaging
- Mirror Image Control
- Auto Sensing 12VDC or 24VAC with Line Lock
- No Fog or Condensation under Any Weather Condition

ADJUSTMENT OF BACK FOCUS

1. Please make sure the lens is C or CS Mount.

To use C Mount lens, please fix the lens into front camera after mounting the included C ring to the lens.

To use CS Mount lens, fix the lens directly into the front camera without the C ring.

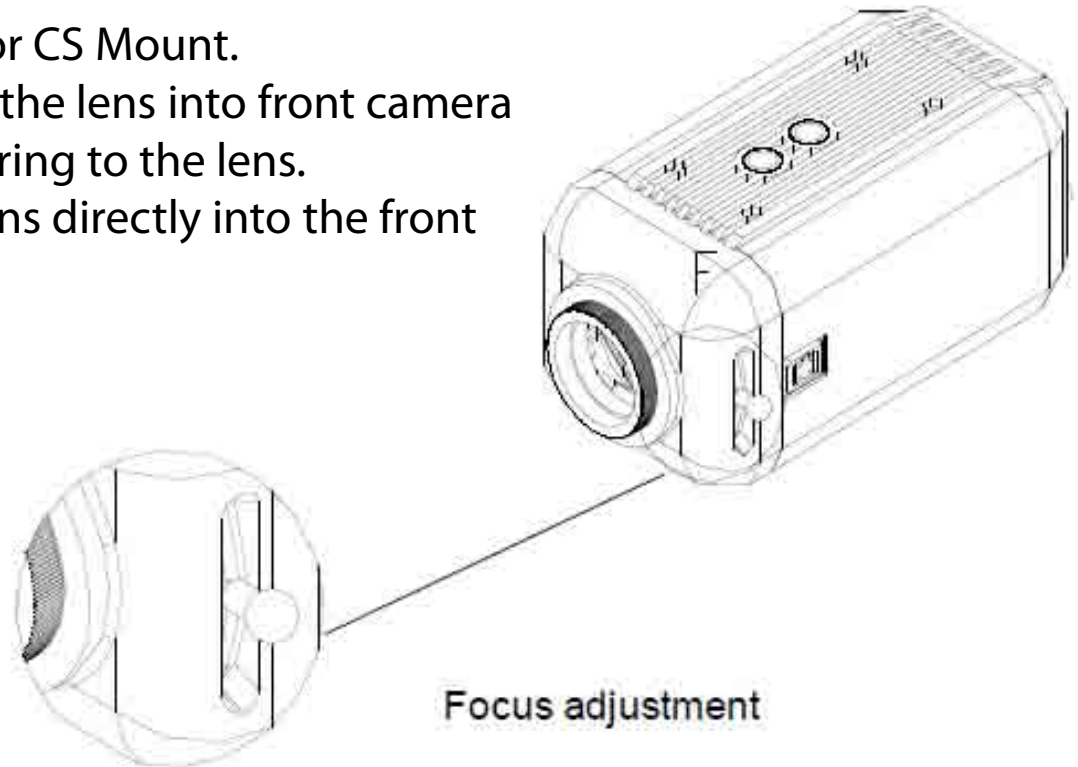

2. To adjust the focus, slide the focus lever on the side of the front camera.

3. Please tighten the focus lever after the adjustment in order to prevent being out of focus.

DIMENSIONS (mm)

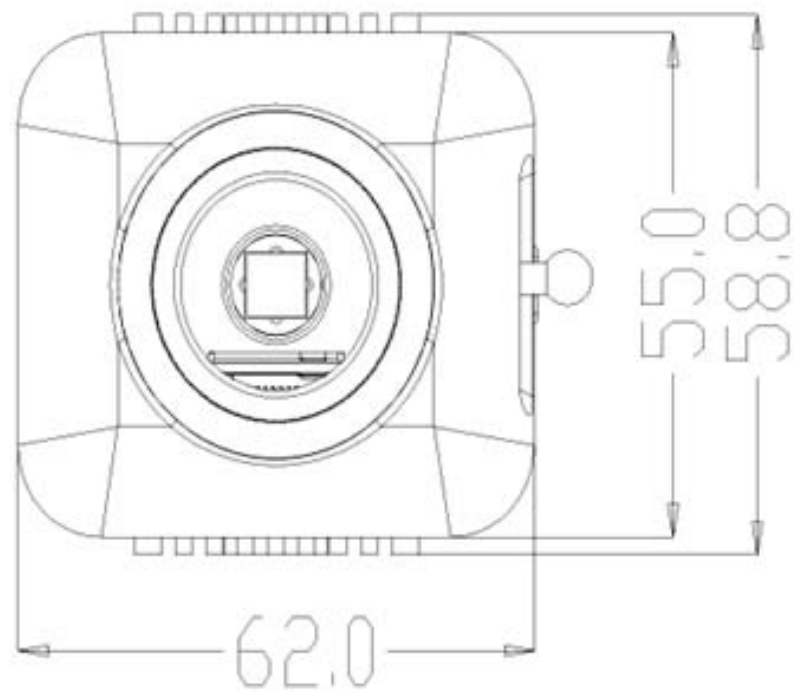
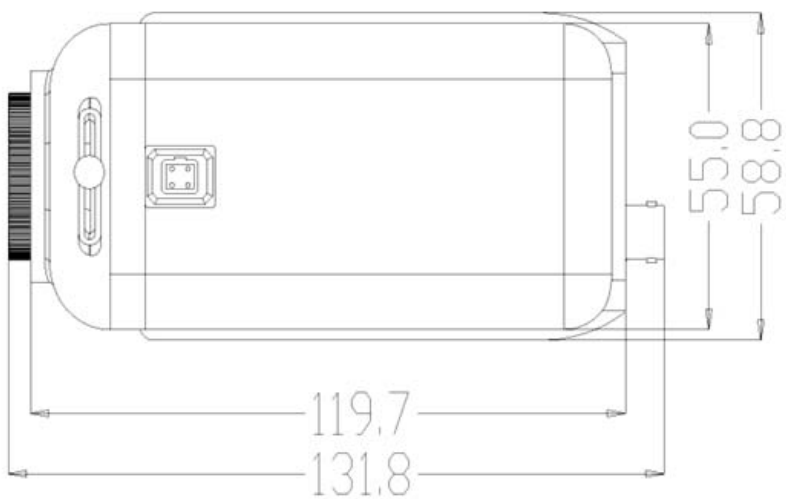
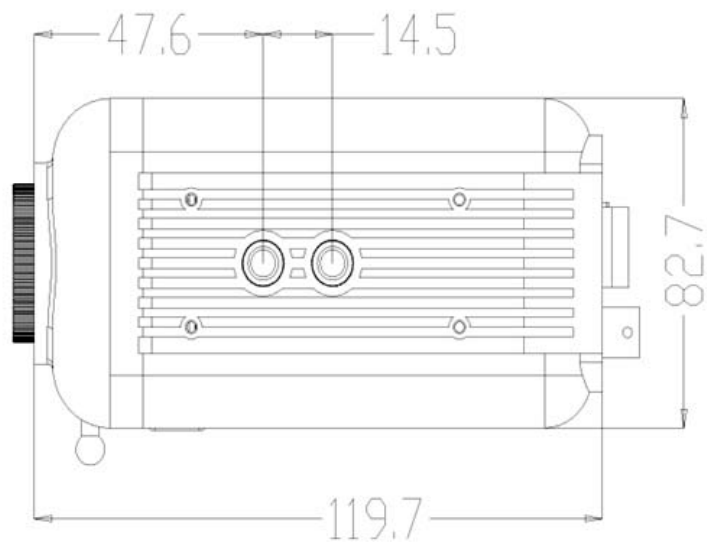

EXPOSURE

LENS	DC (0~100) / MANUAL / VIDEO. (DC Lens is recommended.)
SHUTTER	1/160 / 1/100 / FLC / 1/250 ~ 10000 / SENS-UP x2 ~ x250
BLC	OFF / ON BLC (Back Light Compensation)
AGC	HIGH / MIDDLE / LOW / OFF AGC (Auto Gain Control)
MAX-DR	OFF / ON (0 ~ 20) (Electronic Wide Dynamic Range)
STAR-LIGHT	AUTO (x2 ~ x250) / OFF (x32 is recommended.)
EXIT JUMP	EXIT / SAVE&EXIT / FACTORY RESET

COLOR

WB MODE	AWC / ATW / MANUAL / PUSH LOCK
R-Y GAIN	0 ~ 100
B-Y GAIN	0 ~ 100

DAY & NIGHT

Day & Night Mode	<p>AUTO / COLOR / BW / EX-CONT</p> <p>COLOR ----> BW : Switching from color to BW; if the number is higher, the camera will only switch during a super low light condition. BW ----> COLOR : Switching from BW to color; this number should always be lower than COLOR to BW Read Time: Time interval to switch from Color to Black-and-White</p>
	COLOR
	B&W: (BURST:OFF/ON) When the burst is OFF will make less noise
C-SUP	Color Suppression :Color will be reduced at low illumination, if the C-SUP Level is higher. 0 ~ 100 (Not Available when DNR is On.)
A-SUP	Aperture Suppression : The sharpness of the edges will be reduced at low illumination, if A-SUP Level is higher. 0 ~ 100 (Not Available when DNR is On.)
EXIT JUMP	EXIT / SAVE&EXIT / FACTORY SET

FUNCTION

MIRROR	OFF / MIRROR / V-FLIP / ROTATE
SHARPNESS	0 ~ 31
GAMMA	0.05 ~ 1.00 / USER
FREEZE	OFF / ON
NEGATIVE	OFF / ON
3D-DNR	OFF / LOW / MIDDLE / HIGH 3D-DNR (3D Digital Noise Reduction)
D-ZOOM	OFF / ON (x1.0 ~ x32 PTZ)
SLC	OFF / ON SLC (Side Light Compensation)
HME	OFF / ON HME (Highlight Masking Exposure)
DIS	OFF / ON DIS (Digital Image Stabilizer)
EXIT JUMP	EXIT / SAVE&EXIT / FACTORY SET

MOTION (OMNI-Focus Lens Only)

MOTION	OFF / ON
	SET WINDOW
	ALL SET (Set the Entire Screen)
	ALL CLEAR (Clear the Entire Screen)
	SENSITIVITY (1 ~ 120)
	SHOW INDICATOR (OFF / ICON / TRACE)
	DELAY OUT (1 ~ 15) Motion Alarm Zoom-In Delay
EXIT JUMP	EXIT / SAVE&EXIT / FACTORY SET

PRIVACY

MASK 1 OFF / ON 

MASK 2 OFF / ON 

MASK 3 OFF / ON 

MASK 4 OFF / ON 

MASK 5 OFF / ON 

MASK 6 OFF / ON 

EXIT JUMP

EXIT / SAVE&EXIT / FACTORY SET

SETUP

CAMERA ID

0 ~ 255

TITLE

OFF / ON

DPC

OFF / AUTO
DPC (Dead Pixels Cancellation)

MONITOR

CRT / LCD

LANGUAGE

English, Japanese, Chinese

BAUDRATE

2400 / 4800 / 9600 / 14400 / 19200 / 38400.
Protocol is Pelco-D (fixed cannot be changed; hardcoded into the DSP)

OMNI LENS

OFF / 1 ~ 10 (for OMNI-PLUS CAMERA only)

EXIT JUMP

EXIT / SAVE&EXIT / FACTORY SET

SYNC

SYNC

INTERNAL / AUTO

V-PHASE

0 ~ 199

EXIT JUMP

EXIT / SAVE & EXIT / FACTORY SET

EXIT

EXIT

Exit the menu

SAVE&EXIT

Exit the menu and save the setting

FACTORY SET

Reset the menu setting to factory default

SPECIFICATIONS:



5436 W Crenshaw St. Tampa, FL 33634

Tel: 866-446-3595 / 813-888-9555

Fax: 813-888-9262

www.Digital-Watchdog.com

technicalsupport@dwcc.tv

Technical Support Hours: Monday-Friday

8:30am to 8:00pm Eastern Time



Camera TYPE	Color / BW	C233W
	Mount	3D Bracket
Image	Device	Super HAD II CCD
	Size	1/3"
	Pixels-Total	811(H) x 508 (V)
	Pixels-Effective	768(H) x 494 (V)
Scanning	System	525 line, 2:1 Interlace
	Horizontal Frequency Internal Mode	15,734Hz
	Vertical Frequency Internal Mode	59.94Hz
Min. Scene Illumination	F1.2 x256 Star-Light	0.14 Lux 0.0005 Lux in Color
Functions	BLC	ON / OFF
	AGC	HIGH / MIDDLE / LOW / OFF
	MAX-DR	OFF / ON
	Mirror	OFF / MIRROR / V-FLIP / ROTATE
	STAR-LIGHT	AUTO (x2 ~ x250) / OFF
	3D-DNR	OFF / ON
	SLC	OFF / ON
	HME	OFF / ON
	DIS	OFF / ON
	Privacy Zone	6 Programmable Zone / Size
Lens	Focal Length	3.3~12mm Varifocal Auto Iris Lens
Resolution	Horizontal	560 TV Lines [Color]; 580 TV Lines [BW]
Video Output	VBS 1.0Vp-p	VBS 1.0Vp-p(75 Load)
S/N Ratio	S/N Ratio	50dB
OSD	OSD	YES
Environmental Conditions	Operating Temperature	-10°C ~ +55°C(14°F ~ 131°F)
	Humidity	Less than 90%
Power	Power Requirement	12VDC / 24VAC
	Power Consumption	1.8 [W] / 2.4 [W]