

960H Indoor Dome Camera

DWC-D562D

DWC-D562DIR

User Manual



ABOUT MANUAL

Before installing and using the camera, please read this manual carefully.
Be sure to keep it handy for future reference.

960H Value

PRECAUTIONS

- Do not open or modify.
- Do not open the case except during maintenance and installation, for it may be dangerous and can cause damages.
- Do not put objects into the unit.
- Keep metal objects and flammable substances from entering the camera. It can cause fire, short-circuits, or other damages.
- Be careful when handling the unit.
- To prevent damages, do not drop the camera or subject it to shock or vibration.
- Do not install near electric or magnetic fields.
- Protect from humidity and dust.
- Protect from high temperature.
- Be careful when installing near the ceiling of a kitchen or a boiler room, as the temperature may rise to high levels.
- Cleaning: To remove dirt from the case, moisten a soft cloth with a soft detergent solution and wipe.
- Mounting Surface: The material of the mounting surface must be strong enough to support the camera.

FCC COMPLIANCE

This equipment has been tested and found to comply with the limits for a Class B digital device, pursuant to part 15 of the FCC rules. These limits are designed to provide reasonable protection against harmful interference when the equipment is operated in a residential environment. This equipment generates, uses, and radiates radio frequency energy; and if it is not installed and used in accordance with the instruction manual, it may cause harmful interference to radio communications.

WARNING: Changes or modifications are not expressly approved by the manufacturer.

Table of Contents

Introduction	Features	4
	Parts and Descriptions	5
	Dimensions	6
Installation	Included Accessories	7
	Easy Installation	8
	Base Installation	9
	Connecting to Monitors	10
	Adjusting the Camera	11
	Adjusting the 3-Axis Gimbal	12
Camera OSD Menu and Glossary		13-24
Troubleshooting		25
Warranty Information		26-27
Specifications		28-29

FEATURES*

DWC-D562D / DWC-D562DIR

- 1/3" 960H High Resolution CCD
- 700 TV Lines
- 2.8 ~ 11mm Varifocal Auto Iris Lens
- Electronic Day and Night
- HME (Highlight Masking Exposure)
- AGC / SMART BLC / AWB
- Night-Up
- Mirror Image Control
- Programmable Privacy Zones (8) & Motion Detection
- Easy Icon Driven OSD Menu with Built-In Joystick
- Auto Sensing 12VDC or 24VAC with Line Lock
- Secondary Video-BNC Output
- Video Test Output Included
- 85ft Range IR with Intelligent Camera Sync (DWC-D562DIR only)

PARTS & DESCRIPTIONS*

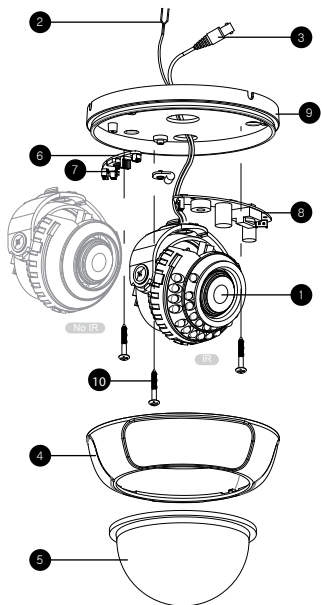

- 1 Lens
- 2 Power Input Connector
12VDC/24VAC Dual Voltage
- 3 Video Output Connector - BNC
- 4 Upper Case
- 5 Dome Cover
- 6 Control Board
- 7 Joystick
- 8 Power Board
- 9 Camera Base
- 10 Mounting Screws

DIMENSIONS IN MILLIMETERS (INCHES)*

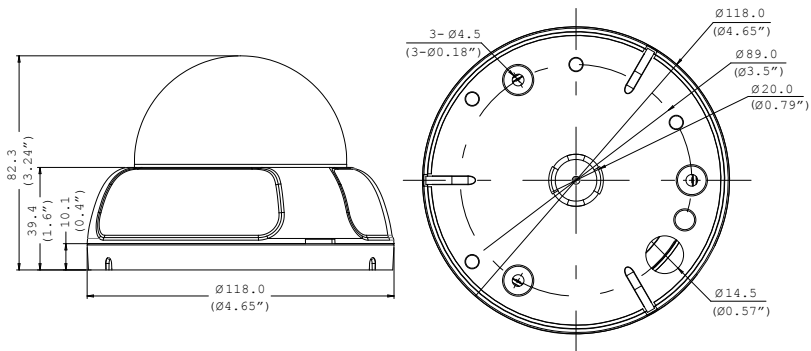

INSTALLATION*

Included with Value Line Indoor Dome Camera

1. User Manual
2. Mounting Template
3. Second Video Jack
4. Mounting Screws (3)

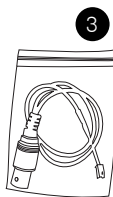
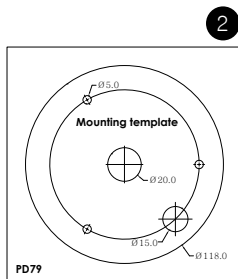
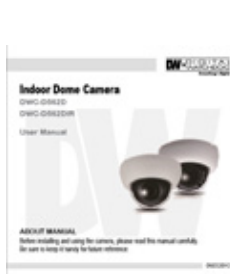

EASY INSTALLATION*

Install the Enclosure Cover

To install the dome cover, align the dome cover with the camera base and push until it securely snaps into place.

Dome Cover

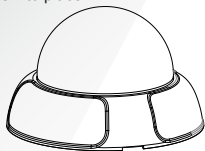

Camera Base

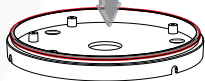

Remove the Dome Cover

Before you can mount or adjust your Value Line Indoor Dome Camera, you must remove the dome cover. Insert a coin or screwdriver in the slot on the dome cover, then twist to pry the dome cover from the camera base.

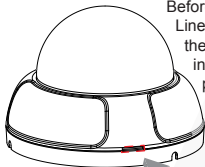

BASE INSTALLATION*



1. Pull wires through and make connections. Refer to page 10. Use mounting template to mount camera with dry wall mounts and wood screws.



2. Adjust the camera's 3-Axis Gimbal, focus, and zoom. See pages 11-12 for details.



3. Press the joystick button to open the OSD menu. Push the joystick left, right, up, or down to navigate the OSD menu. See pages 13-24 for details.



4. Snap the dome cover onto the camera base.

CONNECTING TO MONITORS*

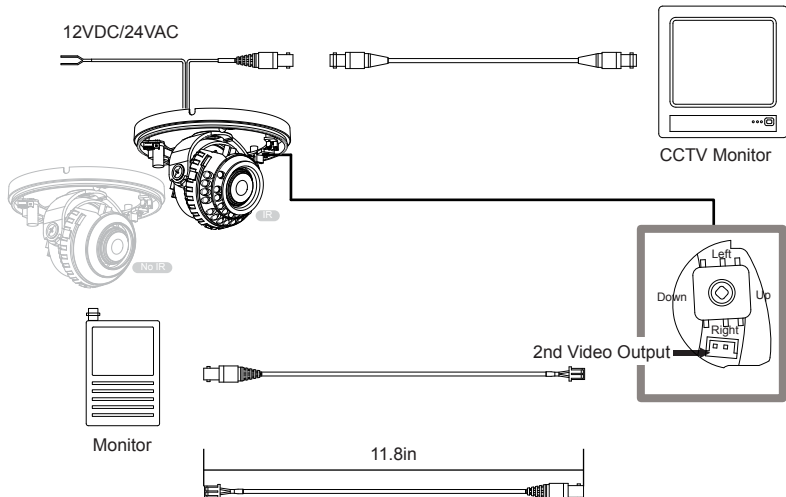

- Power connection - 12VDC/24 VAC Dual Voltage. (Auto polarity detection and protection.)
- All cameras are equipped with a second video output on the camera's Control Board for easy on-site configuration.

ADJUSTING THE CAMERA*

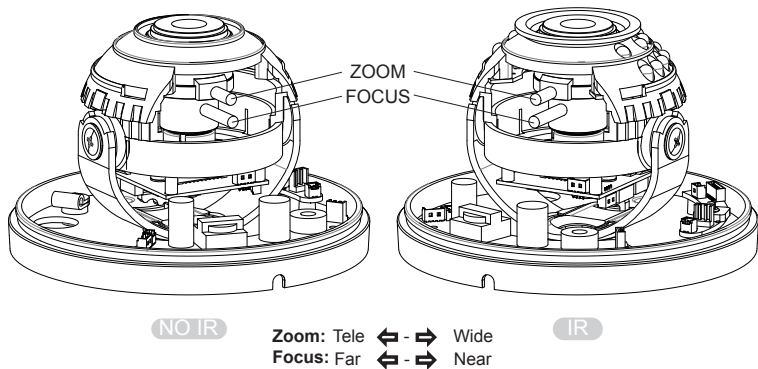

- 1 Loosen the zoom and focus handles by rotating them counter-clockwise.
- 2 Adjust the field of view by moving the handle to the RIGHT (tele) to zoom in, or to the LEFT (wide) to zoom out.
- 3 Adjust the focus the same way as described above AFTER the desired zoom position is established.
- 4 Once the desired adjustments have been made, please tighten the handles back by turning them clockwise.

ADJUSTING THE 3-AXIS GIMBAL*

The Gimbal mechanism yields maximum rotation and placement as shown below.

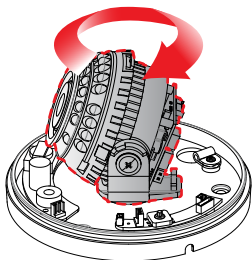

1 Rotation 360°

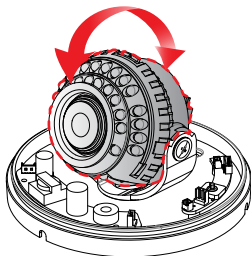

2 Tilting 70°

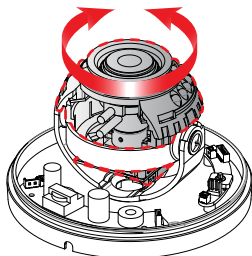

3 Panning 360°

MODULE OSD MENU*

EXPOSURE	COLOR	DAY NIGHT
<ul style="list-style-type: none"> — LENS MANUAL, DC — BACKLIGHT OFF / BLC / HME / D-WDR — AGC OFF / LOW / MID / HIGH / HIGHEST — 2D-DNR OFF / LOW / MIDDLE / HIGH — EXIT JUMP SAVE & EXIT / EXIT 	<ul style="list-style-type: none"> — WB MODE AWC / ATW / MANUAL / PUSH — RED GAIN 0-255 — BLUE GAIN 0-255 — COLOR MODE NORMAL / COOL / WARM — EXIT JUMP SAVE & EXIT / EXIT 	<ul style="list-style-type: none"> — DAY & NIGHT AUTO / COLOR / B&W — NIGHT C. 0-100 — NIGHT A. 0-100 — EXIT JUMP SAVE & EXIT / EXIT
FUNCTION	MOTION	PRIVACY
<ul style="list-style-type: none"> — MIRROR MIRROR / OFF — SHARPNESS 0-30 — GAMMA MANUAL / 0.45 / 0.60 / 1.0 — SLC OFF / ON — NIGHT-UP OFF / ON — EXIT JUMP SAVE & EXIT / EXIT 	<ul style="list-style-type: none"> — AREA SET AREAS 1-4, OFF / ON — SENSITIV. 1-30 — SHOW INDL OFF / ICON / TRACE — EXTER-OUT. OFF / ON — EXIT JUMP SAVE & EXIT / EXIT 	<ul style="list-style-type: none"> — MASK1 OFF / ON — MASK2 OFF / ON — MASK3 OFF / ON — MASK4 OFF / ON — MASK5 OFF / ON — MASK6 OFF / ON — MASK7 OFF / ON — MASK8 OFF / ON — EXIT JUMP SAVE & EXIT / EXIT
SET-UP	EXIT	
<ul style="list-style-type: none"> — TITLE OFF / ON — DPC SET OFF / AUTO — MONITOR MODE1 / MODE2 — LANGUAGE ENGLISH / 繁體中文 / 簡體中文 / 日本語 DEUTSCH, FRENCH, ITALIAN, RUSSIAN, SPANISH, DUTCH — OSD COLOR BLUE / GREEN / CYAN / RED / MAGENTA, YELLOW / PURPLE / GRAY — COMMUNICA. OFF / ON — FACTORY SET. NO / YES — EXIT JUMP SAVE & EXIT / EXIT 	<ul style="list-style-type: none"> — SAVE & EXIT — EXIT 	



EXPOSURE

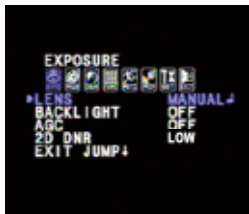

LENS

MANUAL MANUAL mode supports the fixed board lens or the manual iris lens.

DC DC mode supports the auto-iris varifocal lens.

Note:

Both MANUAL and DC mode have FOCUS TARGET.

You can adjust the focus by finding the highest number on the FOCUS TARGET. See page 11 for Focus information.



ELC levels and DC levels are adjustable. The higher the number, the brighter the images.

E. Shutter sets the shutter speed levels from 1/60 to 1/100000.

AUTO and DC-AUTO are the default shutter speeds for both indoor and outdoor use.

Select 1/100FLC to run camera in flickerless mode.



EXPOSURE

BACKLIGHT

OFF

BLC

BACKLIGHT COMPENSATION

Select MANUAL or SMART. **SMART** is recommended.



If MANUAL is selected, you can adjust the BLC level in four areas of the scene (Top, Bottom, Left, Right). Increase the BLC level where you want to make the image brighter.



If SMART is selected, the camera will automatically adjust the BLC zone. BLC levels to choose from include: LOWEST, LOW, MID, HIGH.

HME

HIGHLIGHT MASKING EXPOSURE

HME masks highlights to allow objects to appear clearly on the screen. If ON is selected, HME levels are adjustable. The lower the number, the darker the masking areas.



D-WDR

DIGITAL WIDE DYNAMIC RANGE

D-WDR is one of the backlight compensation functions. You can adjust the D-WDR level from 0-20. The lower the number, the brighter the backlight.

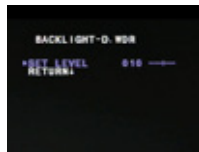



EXPOSURE

AGC (Auto Gain Control)

OFF / LOW / MID / HIGH / HIGHEST

AGC enhances picture brightness in low light conditions. A higher AGC setting makes the image brighter; however, it could cause an increase in noise.

2D-DNR (Digital Noise Reduction)

OFF / LOW / MIDDLE / HIGH

2D-DNR reduces noise on the screen in low light conditions. It allows for clearer images, even at night.

EXIT_JUMP

SAVE & EXIT
EXIT

Exit the OSD after saving the current settings.
Exit the OSD without saving.



COLOR



WB MODE

- AWC** Auto White Balance Control mode compensates for color temperature changes between 2000K and 18000K.
- ATW** Auto Tracking White Balance Control mode compensates for color temperature changes between 2500K and 9500K.
- MANUAL** Users can control the white balance manually by changing RED GAIN and BLUE GAIN (see below).
- PUSH LOCK** Push Lock fixes the white balance based on current lighting.

RED GAIN

0-255 Adjusts the amount of red in the image.

BLUE GAIN

0-255 Adjusts the amount of blue in the image.

COLOR MODE

- NORMAL** Color is similar to actual color.
- COOL** Color has more blue.
- WARM** Color has more red.

EXIT_JUMP

- SAVE & EXIT** Exit the OSD after saving the current settings.
- EXIT** Exit the OSD without saving.



DAY NIGHT



D&N MODE

- AUTO** Camera switches between day and night automatically depending on light level. Camera will stay in color mode when there is enough light. Camera will switch to B&W at night or other low light environments.
- COLOR** Camera always stays in day/color mode.
- B&W** Camera always stays in night mode.

If AUTO is selected, please define the following settings:

- **BURST: ON/OFF.** If ON is selected, the camera provides a color burst signal in night mode. If OFF, no color burst signal is provided.
- **COLOR → B&W:** Adjusts the light level at which the camera switches from day (color) to night (B&W) mode. The higher the number, the lower the light level.
- **B&W → COLOR:** Adjusts the light level at which the camera switches from night (B&W) to day (color) mode. This number should be lower than the value of COLOR → B&W above.
- **SMART IR: ON/OFF.** If using IR LEDs, ON is recommended.
- **READ TIME:** Time interval delay before switching from day mode to night mode. It is adjustable from 3 seconds to 12 seconds.
- **EX_IR INT.: AUTO/EXT.** If using IR LEDs built into the camera, select AUTO. If using external IR LEDs separately, select EXT.

NIGHT C.

0~100

Color will be reduced in low light conditions.
(This level cannot be adjusted when 2D-DNR is ON.)

NIGHT A.

0~100

Edge sharpness will be reduced in low light conditions.
(This level cannot be adjusted when 2D-DNR is ON.)

EXIT_JUMP

SAVE & EXIT
EXIT

Exit the OSD after saving the current settings.
Exit the OSD without saving.



FUNCTION



MIRROR

OFF

MIRROR

Flips the image horizontally.

SHARPNESS

0~30

Sets the image sharpness. The higher the number, the sharper the image.

GAMMA

0.45/ 0.6/ 1.0
/MANUAL

Controls the output signal level. The higher the setting, the darker the dark colors will be. 0.45 is default.

SLC (Side Light Compensation)

OFF/ ON

Increases brightness on sides of the image.

NIGHT-UP

OFF/ ON

Adjusts sensitivity in low light conditions by set-up level. If ON is selected, the set-up level becomes higher and the images become brighter.

EXIT_JUMP

SAVE & EXIT
EXIT

Exit the OSD after saving the current settings.
Exit the OSD without saving.



MOTION

The camera can detect movement and display an alarm on the screen when movement is detected.



AREA SET

AREA 1,2,3,4

OFF/ON

If ON, motion areas can be selected and moved accordingly. Select Areas 1-4 and adjust using controls for TOP, BOTTOM, LEFT, or RIGHT.



SENSITIV.

1~30

Sensitivity level of motion detection is adjustable.

Motion detection will be more sensitive at a higher number.

SHOW INDI.

OFF / ICON / TRACE

Set the Show Indicator to OFF, ICON, or TRACE. If ICON is selected, a bell will appear in the upper right hand corner when motion is detected. If TRACE is selected, the area where motion was detected will be highlighted.

EXTER OUT

OFF/ ON

ALARM SIGNAL EXTERNAL OUTPUT

If ON is selected, you can set how long the alarm is displayed on the screen when motion is detected (0~15 seconds).



EXIT_JUMP

SAVE & EXIT
EXIT

Exit the OSD after saving the current settings.

Exit the OSD without saving.



PRIVACY



You can hide some parts of the screen for privacy masking. A total of 8 different privacy masking zones are available.

MASK 1~ MASK 8

OFF / ON Select ON or OFF for each mask.

If ON is selected, you can set the area to be masked and the shape and color of the mask.

- **START POINT:**
Select the START POINT to adjust the size of the privacy zone.
 - L_TOP - Left Top
 - R_TOP - Right Top
 - L_BOT - Left Bottom
 - R_BOT - Right Bottom
- **MODIFY:**
After selecting the START POINT, you can modify the size of the privacy zone by moving the joystick.
- **POSITION:**
Move the privacy zone by moving the joystick.
- **COLOR SET:**
Privacy Zones can be set with 8 different colors - GRAY, BLACK, WHITE, RED, GREEN, BLUE, MAGENTA, CYAN.



SET-UP



TITLE

OFF
ON

If ON is selected, you can display the camera title on the screen.

*CLR: Clear the title.

*POS: Select position of the title on the screen.



DPC (Dead Pixel Cancellation)

OFF

AUTO

Dead Pixel Cancellation automatically removes defective pixels in real time.



If AUTO is selected, you can define the following:

*WHITE THR.: Cancels the white defective pixels.

*BLACK THR.: Cancels the black defective pixels.

*DPC LEVEL: Adjusts the sensitivity level of the dead pixel cancellation.

Note: Adjust the WHITE THR., BLACK THR. and DPC LEVEL at the same time.



SET-UP

MONITOR

MODE 1 / MODE 2

MODE 1 is the default. If the displayed image is not adequate, try MODE 2.

LANGUAGE

A total of 10 different languages are supported: ENGLISH, MANDARIN (CHINESE 1), CANTONESE (CHINESE 2), JAPANESE, DEUTSCH, FRENCH, ITALIAN, RUSSIAN, SPANISH, AND DUTCH.

OSD COLOR

A total of 8 menu colors are available: BLUE, GREEN, CYAN, RED, MAGENTA, YELLOW, PURPLE, AND GRAY.

COMMUNICATION

OFF / ON



If ON is selected, you can define the following:

- *PROTOCOL: PELCO-D only.
- *CAMERA ID: Provide the ID no. on the camera (0~255).
- *BAUDRATE: 9600bps is the default.
(There are a total of 4 choices: 2400bps, 4800bps, 9600bps, and 19200bps.)

FACTORY SET

If selected, the camera reverts back to factory default settings.

Note: FACTORY SET does not affect the LENS, DAY & NIGHT, CAMERA ID, and DPC settings.

EXIT_JUMP

SAVE & EXIT

EXIT

Exit the OSD after saving the current settings.

Exit the OSD without saving.



EXIT

EXIT

SAVE & EXIT

EXIT

Exit the OSD after saving the current settings.

Exit the OSD without saving.

TROUBLESHOOTING

Before sending your camera for repair, check the following or contact one of our technical specialists.

No VIDEO

Check the coaxial cable and make sure it is connected securely.

Check the lens' iris adjustment on the menu setup of the camera.

Check the power supply and make sure the camera has the proper voltage and current.

Out-of-Focus VIDEO

Check the clear dome cover and the lens for dirt or fingerprints. Use a soft cloth and gently clean.

Check the lens manual focal and zoom adjustment. A field test monitor is recommended.

WARRANTY INFORMATION*

Digital Watchdog (referred to as “the Warrantor”) warrants the Digital Watchdog Camera against defects in materials or workmanship as follows:

LABOR: For the initial two (2) years and one (1) year on IR LED from the original purchase date, if the camera is determined to be defective, the Warrantor will repair or replace the unit with a new or refurbished product at its option at no charge.

PARTS: In addition, the Warrantor will supply replacement parts for the initial two (2) years and one (1) year on IR LED.

To obtain warranty or out of warranty service, please contact a Technical Support Representative at **1-866-446-3595** Monday through Friday from 8:30AM to 8:00PM Eastern Standard Time.

A purchase receipt or other proof of the original purchase date is required before warranty service is rendered. This warranty only covers failures due to defects in materials and workmanship which arise during normal use. This warranty does not cover damage which occurs in shipment or failures which are caused by products not supplied by the Warrantor or failures which result from accident, misuse, abuse, neglect, mishandling, misapplication, alteration, modification, faulty installation, set-up adjustments, improper antenna, inadequate signal pickup, maladjustment of consumer controls, improper operation, power line surge, improper voltage supply, lightning damage, rental use of the product, or service by anyone other than an authorized repair facility or damage that is attributable to acts of God.

LIMITS AND EXCLUSIONS*

There are no express warranties except as listed.

The Warrantor will not be liable for incidental or consequential damages (including, without limitation, damage to recording media), resulting from the use of these products or arising out of any breach of the warranty. All express and implied warranties, including the warranties of merchantability and fitness for particular purpose, are limited to the applicable warranty period set forth above.

Some states do not allow the exclusion or limitation of incidental or consequential damages, or limitations on how long an implied warranty lasts, so the exclusions or limitations listed above may not apply to you. This warranty gives you specific legal rights, and you may also have other rights that vary from state to state.

If the problem is not handled to your satisfaction, then write to the address listed on the last page.

Service calls which do not involve defective materials or workmanship as determined by the Warrantor, in its sole discretion, are not covered. Costs of such service calls are the responsibility of the purchaser.

SPECIFICATIONS*

VIDEO	
Image Sensor	960H Sharp CCD
Total Pixels	1020 (H) x 507 (V), 520K Pixels
Scanning System	2 : 1 Interlace
Frequency	15.734KHz (H), 59.95Hz (V)
Synchronization	Internal
Horizontal Resolution	650 TV Lines [Color], 700 TV Lines [B/W]
Minimum Illumination	F1.2 (30IRE): 0.3 Lux [Color]
	F1.2 (30IRE): 0.0 Lux [B/W]
S/N Ratio	52dB (AGC off)
Video Output	CVBS: 1.0Vp-p / 75 Ω
LENS	
Focal Length	2.8-11mm
Lens Type	DC Auto Iris
IR Distance	85ft Range
OPERATIONAL	
Lens	MANUAL, DC (000-100)
Backlight Compensation	OFF, BLC, HME, DIGITAL WDR
Auto Gain Control	OFF, LOW, MID, HIGH, HIGHEST
White Balance	AWC, ATW, MANUAL, PUSH
Color Mode	NORMAL, COOL, WARM
Day and Night	AUTO, COLOR, B&W
Mirror	OFF, MIRROR

OPERATIONAL

Sharpness	0-30
Gamma	MANUAL, 0.45, 0.60, 1.00
Side Light Compensation	OFF, ON (0-30)
Night Up	OFF, ON
Motion Detection	OFF, ON (4 Programmable Zones)
Privacy Zones	OFF, ON (8 Programmable Zones)
Title	OFF, ON (Up to 16 Characters)
Dead Pixel Cancellation	OFF, AUTO
Communication Protocol	PELCO-D

ENVIRONMENTAL

Operating Temperature	-10°C ~ 55°C (14°F ~ 131°F)
Operating Humidity	Less than 90% (Non-Condensing)
Storage Temperature	-20°C ~ 70°C (-4°F ~ 158°F)

ELECTRICAL

Power Requirement	Dual (DC12V & AC24V)
Power Consumption	DC12V: 1.6W / LED ON 4.3W
	AC24V: 1.9W / LED ON 4.0W

MECHANICAL

Housing Material	Plastic
Dome Cover Material	Polycarbonate
Dimensions	∅118 X 82.3 mm (∅4.65 X 3.24 in)
Weight	0.54 lbs

*Specification is subject to change without prior notice.

MEMO



MEMO





5436 W. Crenshaw St. Tampa, FL 33634

Tel : 866-446-3595

Fax : 813-888-9262

www.Digital-Watchdog.com

technicalsupport@dwcc.tv

Technical Support Hours : Monday-Friday
8:30am to 8:00pm Eastern Standard Time