

Snapit

HD-SDI Indoor Dome Camera

DWC-HD421D

DWC-HD421TIR



ABOUT MANUAL

Before installing and using the camera, please read this manual carefully.
Be sure to keep it handy for future reference.

PRECAUTIONS

- Do not open or modify.
- Do not open the case except during maintenance and installation, for it may be dangerous and can cause damages.
- Do not put objects into the unit.
- Keep metal objects and flammable substances from entering the camera.
It can cause fire, short-circuits, or other damages.
- Be careful when handling the unit.
- To prevent damages, do not drop the camera or subject it to shock or vibration.
- Do not install near electric or magnetic fields.
- Protect from humidity and dust.
- Protect from high temperature.
- Be careful when installing near the ceiling of kitchen or a boiler room, as the temperature may rise to high levels.
- Cleaning:
To remove dirt from the case, moisten a soft cloth with a soft detergent solution and wipe.
- Mounting Surface:
The material of the mounting surface must be strong enough to support the camera.

FCC COMPLIANCE

This equipment has been tested and found to comply with the limits for a Class B digital device, pursuant to part 15 of the FCC rules. These limits are designed to provide reasonable protection against harmful interference when the equipment is operated in a residential environment. This equipment generates, uses, and radiates radio frequency energy; and if it is not installed and used in accordance with the instruction manual, it may cause harmful interference to radio communications.

WARNING: Changes or modifications are not expressly approved by the manufacturer.

TABLE OF CONTENTS

Introduction	Features	4
	Parts and Descriptions	5
	Dimensions	6
Installation	Included Accessories	7
	Easy Installations	8-9
	Connecting to Monitors	10
	Controlling the camera's OSD Remotely	11
	Adjusting the Camera's Lens	12
	Adjusting the 3-Axis Gimbal	13
Camera OSD Menu and Glossary		14-26
Troubleshooting		27
Warranty Information		28-29
Specifications		30-31

FEATURES*

- Sony 1/2.8" CMOS Sensor
- Highest Resolution 2.1 Megapixels
- 720P / 1080P Mode Selectable
- 3.5~16mm Auto-Focus Lens
- 4.5X Optical Zoom
- Double Shutter WDR (Wide Dynamic Range) at 15fps
- 70ft Range IR with Intelligent Camera Sync **[HD421TIR]**
- Electronic Day and Night **[HD421D]**
- True Day and Night **[HD421TIR]**
- AGC / BLC / AWB
- 3D DNR (3D Digital Noise Reduction)
- Digital Zoom (0~112 level)
- HME/ HLMSK (Highlight Masking Exposure)
- Mirror & Image Flip
- Programmable Privacy Zone (30) & Motion Detection
- Dead Pixels Cancellation
- 12VDC Support Only
- Secondary Video-BNC Output

PART & DESCRIPTIONS*

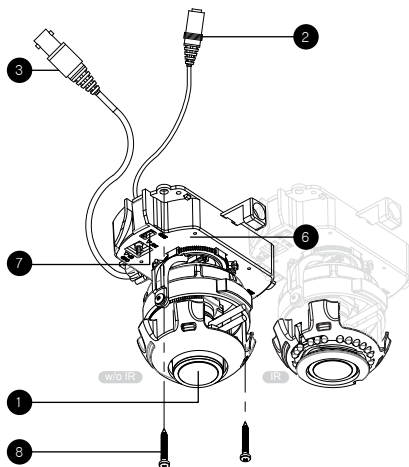

- ① Lens
- ② Power input Connector
12VDC Voltage
- ③ BNC (HD-SDI) + RS485
- ④ Bubble Dome
- ⑤ Upper Case
- ⑥ Camera Control Board
- ⑦ 2nd Video Connector
- ⑧ Mounting Screws

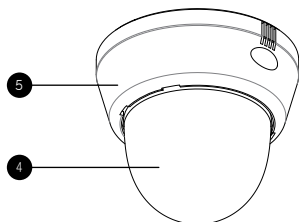

DIMENSIONS IN MILLIMETERS (IN)*

Surface Mount

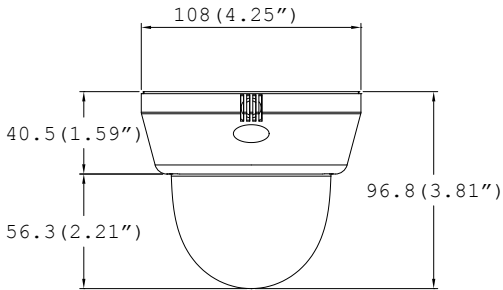

Top View

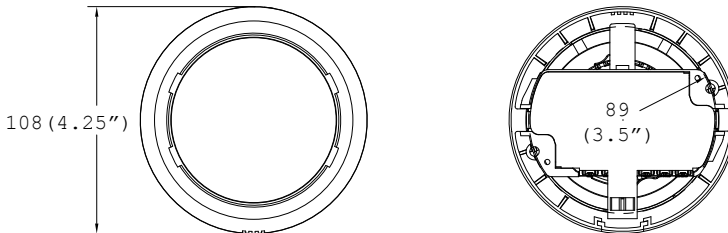

INSIDE THE BOX*

Included with Snapit Indoor Dome Camera

- ① User Manual
- ② Mounting Template
- ③ 2 Machine Screw and 2 Dry Wall Anchors
- ④ Secondary Video-BNC Cable



1

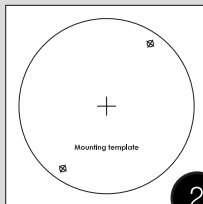

2



3



4

SURFACE MOUNT INSTALLATION INSTRUCTIONS*



- 1 Squeeze the sides of the camera and separate the camera module from the dome cover.



- 2 Use the camera's mounting template or your camera to mark the holes as required.



- 3 Drill holes into the drywall and insert the drywall mounts into the holes.



- 4 Pull wires through and make connections. Then, mount the camera to the wall using the included machine screws.



- 5 Adjust the camera lens position by using the 3-Axis Gimbal.



- 6 Snap the dome cover over the camera module.

WALL MOUNT INSTALLATION INSTRUCTIONS (optional)*



- ① Check to see all parts are in the box.

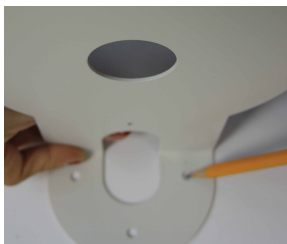

- ② Use the mount to mark the pilot holes are required. Drill holes into the drywall and insert the drywall mounts.



- ③ Secure the wall mount to the wall using the mounting screws.

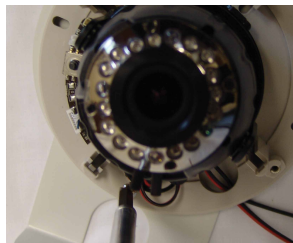

- ④ Attach the base of the camera to the wall mount with the smaller machine screws.



- ⑤ Adjust the camera lens, and snap the dome cover over the camera module.

Note: Mount sold separately.

CONNECTING TO MONITORS*

Use the diagram below to connect the camera to a Monitor or CRT Monitor.

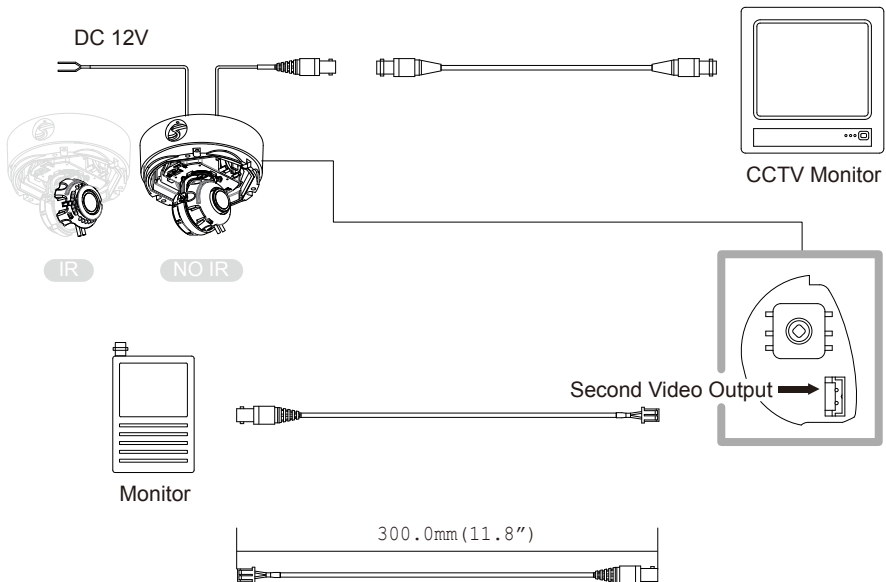

Power Connection: 12VDC Voltage

All cameras are equipped with a second video output for on-site configuration.

CONTROLLING THE CAMERA'S OSD REMOTELY

DWC-HD421D and DWC-HD421TIR, combined with Digital Watchdog's VMAX HD DVR offer the unique feature of controlling the camera's OSD menu, focus, and zoom from the DVR with no additional cables other than the BNC cable.

To setup the camera for remote DVR controlling:

1. Go to the camera's OSD menu and select 'Property'. Make sure the camera is set to NDT-AUX Protocol.
2. If you have multiple Digital Watchdog HD-SDI cameras connected to the same VMAX HD, be sure to assign each camera a different ID. See page 15 for more information.
3. On the DVR side, go to the main menu and select > Device > PTZ. Enter the channel of the camera you wish to setup. Make sure the ID you set in the DVR corresponds with the camera's ID. the camera.
4. Select "FASTRAXII COAX" as the protocol in the DVR menu.

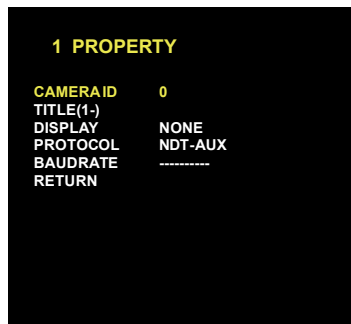

Note: Please refer to the DVR's manual for additional information on setup and camera control.

ADJUSTING THE CAMERA LENS*

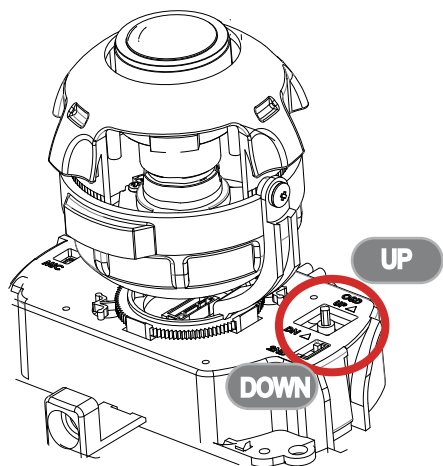

Adjusting the Auto Focus Lens

- 1 Push the OSD joystick 'UP' to zoom-in. Keep holding the joystick until the desired zoom is achieved. Release the joystick to stop zooming. Once the joystick is released, the camera will begin auto-focusing to adjust to the new zoom position.
- 2 Push the OSD joystick 'Down' to zoom-out. Keep holding the joystick until the desired zoom is achieved. Release the joystick to stop zooming. Once the joystick is released, the camera will begin auto-focusing to adjust to the new zoom position.

Note: The camera's Auto-Focus process may take up to 30 seconds.

ADJUSTING 3-AXIS GIMBAL*

The Gimbal mechanism yields maximum rotation and placement as show below.

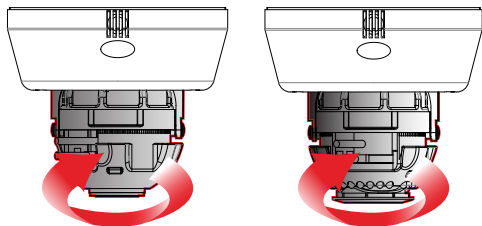

NO IR

Rotation 360°

IR

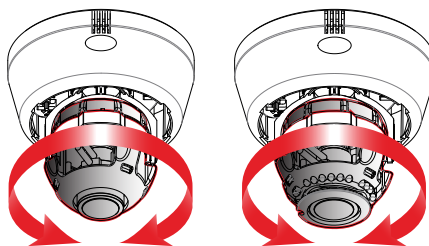

NO IR

Panning 360°

IR

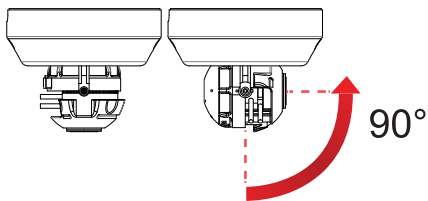

NO IR

Tilting 90°

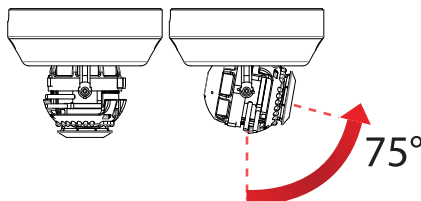

IR

Tilting 75°

Do not over rotate the lens. Doing so will damage the camera lens module.

MODULE OSD MENU*

PROPERTY	EXPOSURE	LENS
<ul style="list-style-type: none"> — CAMERA ID 0~255 — TITLE — DISPLAY NON, ID., TITLE — PROTOCOL NDT-AUX — BAUDRATE ----- — RETURN 	<ul style="list-style-type: none"> — BRIGHTNESS 0~20 — SHUTTER AUTO, MANUAL (1/30~1/60000) — DSS OFF, x2, x3, x4 — AGC 0~20 — RETURN 	<ul style="list-style-type: none"> — LENS TYPE MANUAL, DC, AF — MODE OUTDOOR, INDOOR, FLK, Deblur120, Deblur240 — OPTIC ZOOM TELE, WIDE — FOCUS MODE MANUAL, AUTO — FOCUSING FAR, NEAR — TIMER OFF, 1~10min — TDN SYNC OFF, ON — RETURN
FUNCTION	IMAGE	WDR/BLC
<ul style="list-style-type: none"> — DZOOM 0~112 — AWB AUTO, AUTO_H, AUTO_L, PRESET, AUTO-ext, MANUAL (Kelvin, R-Gain, B-Gain) — PRIVACY OFF, ON (30 masks, setup position, size, & color) — DNR OFF, LOW, MIDDLE, HIGH — MOTION OFF, ON (Resolution, Sensitivity) — RETURN 	<ul style="list-style-type: none"> — CHROMA 0~20 — SHARPNESS 0~10 — MIRROR ON, OFF — FLIP ON, OFF — E-Edge ON, OFF — HLMASK OFF, ON (Level 0~20, Color) — CONTRAST NORMAL, HIGH, HIGHEST — COLOR SET Color1, Color2, Color3 — HUE CONTROL R-GAIN, B-GAIN — RETURN 	<ul style="list-style-type: none"> — MAX DR OFF, ON — MODE OFF, BLC, WDR — WDR_WGT 0~9 — BLC OSD OFF, ON — BLC POS-X 0~20 — BLC POS-Y 0~20 — BLC SIZ-X 0~20 — BLC SIZ-Y 0~20 — RETURN
DAYNIGHT	SET UP	EXIT
<ul style="list-style-type: none"> — TDN MODE AUTO, COLOR, BW, LED — BW to C 0~10 — C to BW 0~10 — CDS SET BW Low, BW High — RETURN 	<ul style="list-style-type: none"> — DETECT DET OFF, ON (00~99, aa-ff) — 2.0M MODE 1080P, 720P — 720P MODE 60/50FPS, 30/25FPS — LANGUAGE ENG, GER, CHN — TDN TEST TEST OFF, TEST ON — FACTORY SET YES, NO — FREQ 60Hz, 50Hz — TYPE DOME, BOX, BULLET — FW_LOCK ON, OFF — RETURN 	<ul style="list-style-type: none"> — EXIT No Save, Yes Save — RETURN

PROPERTY

```

1 PROPERTY

CAMERA ID      0
TITLE(1-)
DISPLAY        NONE
PROTOCOL       NDT-AUX
BAUDRATE       -----
RETURN
  
```

DISPLAY

NONE, ID, TITLE

PROTOCOL

NDT-AUX

BAUDRATE

RETURN

CAMERA ID

0~255 You can define the camera's ID no. from 0~255. For OSD control of multiple cameras, make sure to assign a different ID to each camera. See page 11 for more information.

TITLE

(1-) You can give the camera a unique title 8 symbols long. To set the camera's title, select from the following symbols: 0~9, A~Z, and space.

Example: **HDSDI123.**

```

TITLE (1-H) H
TITLE (2-D) HD
TITLE (3-S) HDS
TITLE (4-D) HDSD
TITLE (5-I) HDSDI
TITLE (5-1) HDSDI1
TITLE (6-2) HDSDI12
TITLE (8-3) HDSDI123
  
```

```

1 PROPEARTY

CAMERA ID      1
TITLE(1-H)     HDSDI123
DISPLAY        NONE
PROTOCOL       PELCO-D
BAUDRATE       9600 BPS
RETURN
  
```

You can select to display the camera's ID or title on the video by selecting the appropriate option.

If you are connecting the camera to Digital Watchdog's VMAXHD DVR, use the default Protocol- NDT-AUX. See page 11 for more information.

9600 is default.

EXPOSURE

2 EXPOSURE

BRIGHTNESS ||| 10
SHUTTER AUTO
DSS OFF
AGC ||| 20
RETURN

BRIGHTNESS

0~20 You can adjust the brightness of the image.
The higher the number, the brighter the image.
Default is 10.

SHUTTER

AUTO The shutter's speed adjusts automatically based on the light available.
MANUAL The shutter speed can be adjusted between 1/30 ~ 1/60000. Available options depend on the Lens-Mode. See page 17 for more information.

SHUTTER

LEVEL 1/30
RETURN

LENS MODE	Available Shutter Speed
OUTDOOR	1/30~1/60000
INDOOR/FLK	1/30 Fixed
DEBLUR120	1/30~1/120
DEBLUR240	1/30~1/240

DSS (Digital Slow Shutter)

OFF, x2, x3, x4 The default is OFF.
Choose x2,3, or x4 for slower shutter.

AGC (Auto Gain Control)

0~20 Auto Gain Control automatically adjusts the video gain to enhance picture brightness in low light conditions. The higher number the better sensitivity.
The default is 20.

RETURN

LENS

3 LENS

```

LENS TYHPE  AF LENS
MODE         DEBLUR120
OPTIC ZOOM  TTTTTTTTTTTT W
FOCUS MODE  AUTO
TIMER       OFF 00:00
TDN SYNC    OFF
RETURN
    
```

LENS TYPE

AF LENS Auto Focus Lens.
 DC LENS Auto-iris Varifocal lens.
 MANUAL Manual iris or Fixed board lens.

3 LENS

```

LENS TYHPE  DC LENS
MODE         DEBLUR120
OPTIC ZOOM  ----
FOCUS MODE  ----
TIMER       ----
TDN SYNC    ----
RETURN
    
```

If DC or Manual modes are selected, the following menu options will be disabled:
 OPTIC ZOOM
 FOCUS MODE
 TIMER
 TDN SYNC

MODE

OUTDOOR
 INDOOR/FLK
 DEBLUR120
 DEBLUR240

Offers full range of electric shutter speed from 1/30~1/60000.
 Sets the shutter speed to 1/30. Use this Lens mode to avoid color rolling.
 Offers electric shutter speed from 1/30~1/120.
 Offers electric shutter speed from 1/30~1/240.
 Both DEBLUR120, DEBLUR240 help avoid motion blur in low light conditions.

OPTIC ZOOM

Zoom Range is adjustable from Tele to Wide.
 Available only if Lens Mode is set to AF. To adjust the optical zoom, move the joystick left and right until the desired zoom is achieved.
 Once the desired zoom is selected, the camera will auto-focus.
 See page 13 for zoom setup outside the OSD menu.

LENS

FOCUS MODE

AUTO

When using Auto Focus Lens, Focus is adjusted automatically. If AUTO is selected, the camera will adjust the focus after every optical zoom adjustment.

You can also set the camera to automatically adjust the focus based on a timer, from once every minute, up to every ten (10) minutes.

MANUAL

If you want to adjust the focus manually, select MANUAL.

The TIMER menu will be replaced by the FOCUSING menu.

The FOCUSING menu allows you to adjust the focus using the far/ near indicators. Use the joystick to achieve the desired focusing level.

3 LENS

```
LENS TYHPE  AF LENS
MODE         DEBLUR120
OPTIC ZOOM  T |■■■■■■■■■■ W
FOCUS MODE  AUTO
TIMER      OFF 00:00
TDN SYNC    OFF
RETURN
```

3 LENS

```
LENS TYHPE  AF LENS
MODE         DEBLUR120
OPTIC ZOOM  T |■■■■■■■■■■ W
FOCUS MODE  MANUAL
FOCUSING  N < - > F
TDN SYNC    OFF
RETURN
```

TDN SYNC

OFF / ON

If selected, the focus will adjust automatically whenever the camera changes from B/W to Color and back.

FUNCTION

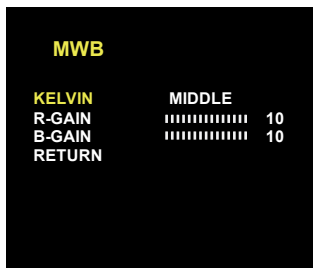
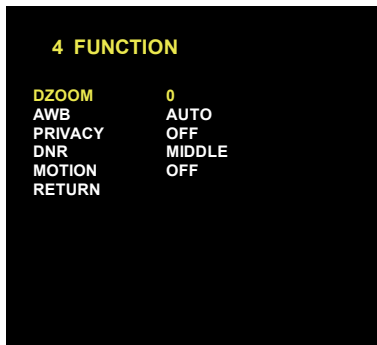

DZOOM

0~112

Digital Zoom function zooms to the center of the image by default. set the zoom level from 0~112.

AWB

AUTO

White Balance is automatically adjusted.

AUTO_H

White Balance is automatically adjusted when the Color temperature is high.

AUTO_L

White Balance is automatically adjusted when the Color temperature is low.

PRESET

White Balance is fixed with current setting.

MANUAL

White Balance is manually adjusted.

AUTO-ext

Select AUTO-ext mode when using external lighting like a hallogen.

If MANUAL mode is selected, define the following menu options:

KELVIN

The color temperature level that will trigger the AWB. Select from LOW / MIDDLE / HIGH

R-GAIN

Adjusts the amount of red in the image. Select from 0~20. The higher the number, the image will appear red. The lower the number, the image will appear green.

B-GAIN

Adjusts the amount of blue in the image. Select from 0~20. The higher the number, the image will appear blue. The lower the number, the image will appear yellow.

FUNCTION

PRIVACY

OFF / ON You can hide some parts of the screen for privacy purposes. A total of 30 privacy masks are available.

PRIVACY	
ZONE NO	0~29
ZONE OP	ON/OFF
X-POS	0~57
Y-POS	0~31
X-SIZ	0~60
Y-SIZ	0~34
COLOR	CYN, GRN, MAG, RED, BLU, BLK, WHT, YEL
TRANS	0~4
RETURN	

ZONE NO	0~29
ZONE OP	Zone Display. ON/OFF
X-POS	X-Position (0~57)
Y-POS	Y-Position (0~31)
X-SIZ	X-Size (0~60)
Y-SIZ	Y-Size (0~34)
COLOR	Privacy Masking Zone Color - CYN, GRN, MAG, RED, BLU, BLK, WHT, YEL
TRANS	Transparency (0~4) Lower number means more transparent.

To setup a Privacy Zone:

1. Go to function menu, and select Privacy ON. Enter the sub-menu. (All 30 masks will appear in their default position).
2. Select the zone number you want to adjust. Select from 0 (top left mask) to 29 (bottom right mask).
3. You can select to show or hide a specific mask by selecting the mask number, going to ZONE OP and selecting ON to display, OFF to hide. (Note: to hide all but one mask, go to each mask number except the one you want to display and select OFF).
4. Use the X-POS to adjust the horizontal location of the mask. Select 0 (far left) ~ 57 (far right).
5. Use the Y-POS to adjust the vertical location of the mask. Select 0 (top of the screen) ~ 31 (bottom of the screen).
6. Use the X-SIZ to adjust the width of the mask. Select 0 (no display) ~ 60 (screen-wide).
7. Use the Y-SIZ to adjust the length of the mask. Select 0 (no display) ~ 34 (screen-tall).
8. If necessary, adjust the color of the mask from the 8 options available.
9. You can adjust the transparency of the mask by selecting 0 (only the outline of the mask is visible) ~ 4 (the entire mask is visible). NOTE: if the mask's transparency is set to 0, playback video will display the mask as an outline only, and the image behind the mask WILL be recorded.

FUNCTION

DNR

Digital Noise Reduction reduces the noise/distortion on the screen in low light conditions, allowing a clear image at night.

Select OFF / LOW / MIDDLE / HIGH.

MOTION

OFF/ON

If selecting ON, define the following menu:

RESOLUTION

Define the size an area with motion has to be to trigger the camera's motion detection. The higher the number, the smaller the area with motion has to be to trigger the camera's motion detection.

SENSITIVITY

Define the level of motion necessary to trigger the camera's motion detection. The higher the number, the more delicate motion can be to trigger the camera's motion detection.



IMAGE

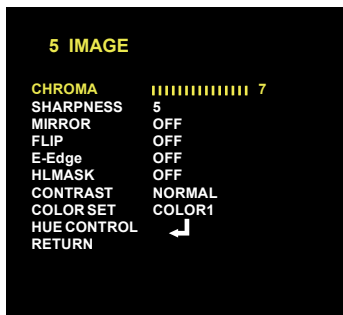

E-Edge

ON/OFF

Edge enhancement. If enabled, edges and fine lines will appear sharper in the image.

HLMASK

OFF

High Lux Masking masks areas in the image that are overexposed to light.

ON

If ON is selected, you can adjust the masking level and color. adjust the level from 0 (only areas with a lot of light will be masked)~10. You can also modify the mask's color from the available 8 options - BLK, WHT, YEL, CYN, GRN, MAG, RED, and BLU



RETURN

CHROMA

0~20

Chroma sets the quality of the color that embraces both hue and saturation. White, black and grays have 0 chroma. The higher numbers accentuate the brighter colors in the image. Default is 7.

SHARPNESS

0~10

Sets the image's sharpness. The higher the number, the sharper lines and details will appear in the image. However, the sharper the image, the more digital noise will be visible.

MIRROR

ON/OFF

Flips the image horizontally. OFF is the default.

FLIP

ON/OFF

Flips the image vertically. OFF is the default.

IMAGE

CONTRAST

NORMAL/ HIGH/ HIGHEST You can adjust the contrast level - Normal, High, and Highest.

COLOR SET

COLOR 1,2,3 Color 1 is the default. If the color reproduction on the monitor is not to your satisfactory, try changing the color mode to Color2 or Color3.

HUE CONTROL

R-GAIN 50 ~180. Adjust the amount of red color in the image. The higher the number, the bolder warm colors will appear.

B-GAIN 50 ~180. Adjust the amount of blue color in the image. The higher the number, the bolder cool colors will appear.

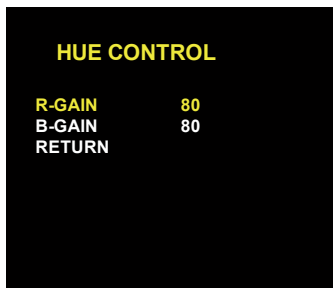

RETURN

WDR/BLC

6 WDR/BLC

MAXDR	OFF
MODE	OFF
WDR_WGT	5
BLC OSD	OFF
BLC POS-X	5
BLC POS-Y	5
BLC SIZ-X	9
BLC SIZ-Y	9
RETURN	

BLC OSD

OFF / ON

Backlight compensation prevents subjects in defined areas from appearing too dark when backlighting is present.
If ON is selected, BLC Zone size and location is adjustable.

BLC POS-X

0~20

Adjusts BLC Horizontal Position.
0= far right side of the screen. 20= far left side of the screen.

BLC POS-Y

0~20

Adjusts BLC Vertical Position.
0= bottom of the screen. 20= top of the screen.

BLC SIZ-X

0~20

Adjusts the width of the BLC Masking area.
0= invisible. 20= screen-wide.

BLC SIZ-Y

0~20

Adjusts the length of the BLC Masking area.
0= invisible. 20= screen-tall.

RETURN

MAX-DR (Digital Wide Dynamic Range)

OFF/ ON

Digital Wide Dynamic Range provides clear images when a strong backlighting is present.

MODE

OFF/ BLC/ WDR

BLC - Back Light Compensation. See information below.

WDR - Wide Dynamic Range (If selected, camera will automatically adjust to 15 frames per second)

WDR_WGT

0~9

Enables the camera to capture clear images in the same frame, even when there are both very bright and very dark areas in the same field.
The higher number, the wider the dynamic range.
The default is 5.

DAY&NIGHT



BW to C

0~9

Adjusts the light level threshold at which the camera switches from night (BW) to day (Color). High number means the higher light level. This number should be LOWER than the value of Color to B/W.

C to BW

0~9

Adjusts the light level threshold at which camera switches from day (Color) to night (BW). High number means the lower light level. This number should HIGHER than the value of B/W to Color.

CDS SET

BW LOW
BW HIGH

Adjusts the filter change signal level when using IR LEDs. BW HIGH is default.

RETURN

TDN MODE

- AUTO The camera switches between day and night automatically depending on the level of light.
- COLOR The camera always stays in day mode (Color).
- BW The camera always stays in night mode (B/W).
- LED LED mode is supported when using external LED light.

SETUP

8 SETUP

DEFECT DET **OFF**
2.0M MODE **1080P**
720P MODE **60/50FPS**
LANGUAGE **ENG**
TDN TEST **TEST OFF**
FACTORY SET **YES**
FREQ **60HZ(NTSC)**
TYPE **BOX**
F/W LOCK **ON**
RETURN

DEFECT DET

OFF / ON Dead Pixel Cancellation automatically removes defective pixels in real time. Consult your installer for setup and additional information.

2.0M MODE

1080P / 720P The camera offers the selection of 2 resolutions: 1080P and 720P.

720P MODE

60/50FPS If resolution 720P is selected, the camera will automatically adjust to 30/25 frames per second. You can also select 60/50FPS if applicable.

30/25FPS

LANGUAGE

ENG/ GER/ CHN Select a language for the OSD menu. Select: English, German, Chinese.

TDN TEST

TEST OFF/ TEST ON True Day & Night test examines the TDN filter in the camera. Consult your installer for setup and additional information.

FACTORY SET

YES/ NO NO is the default. If YES is selected, the camera's settings will return to factory default. Note that all personalized settings will be lost.

FREQ

60HZ, 50HZ Select 60HZ for NTSC, or 50HZ for PAL.

TYPE

DOME, BOX, BULLET Set by manufacturer in the factory. Please do not change.

FW_LOCK

OFF/ ON Firmware Lock Function. This feature is set by default to OFF. It is not recommended to select 'ON'.

RETURN

TROUBLESHOOTING

Before sending your camera for repair, check the following or contact our technical specialist.

FOR NO VIDEO

Check the coaxial cable and make sure it is connected securely.

Check the lens' iris adjustment at the camera's OSD menu.

Check the power supply and make sure the camera has the proper voltage and current.

FOR OUT-OF-FOCUS VIDEO

Check the clear dome cover and the lens for dirt or fingerprints. Use a soft cloth and gently clean.

Check the lens' manual focal and zoom adjustment. The use of a field test monitor is recommended.

WARRANTY INFORMATION*

Digital Watchdog (referred to as “the Warrantor”) warrants the Digital Watchdog Camera against defects in materials or workmanship as follows:

LABOR: For the initial two (2) years and one (1) year on IR LED from the original purchase date, if the camera is determined to be defective, the Warrantor will repair or replace the unit with a new or refurbished product at its option at no charge.

PARTS: In addition, the Warrantor will supply replacement parts for the initial two (2) years and one (1) year on IR LED.

To obtain warranty or out of warranty service, please contact a Technical Support Representative at **1-866-446-3595** Monday through Friday from 8:30AM to 8:00PM Eastern Standard Time.

A purchase receipt or other proof of the original purchase date is required before warranty service is rendered. This warranty only covers failures due to defects in materials and workmanship which arise during normal use. This warranty does not cover damage which occurs in shipment or failures which are caused by products not supplied by the Warrantor or failures which result from accident, misuse, abuse, neglect, mishandling, misapplication, alteration, modification, faulty installation, set-up adjustments, improper antenna, inadequate signal pickup, maladjustment of consumer controls, improper operation, power line surge, improper voltage supply, lightning damage, rental use of the product or service by anyone other than an authorized repair facility or damage that is attributable to acts of God.

LIMITS AND EXCLUSIONS*

There are no express warranties except as listed. The warrantor will not be liable for incidental or consequential damages (including damage to recording media without limitation) resulting from the use of these products or arising out of any breach of the warranty. All express and implied warranties, including the warranties of merchantability and fitness for particular purpose, are limited to the applicable warranty period set forth above.

Some states do not allow the exclusion or limitation of incidental or consequential damages, or limitations on how long an implied warranty lasts, so the exclusions or limitations listed above may not apply to you. This warranty gives you specific legal rights, and you may also have other rights that vary from state-to-state.

If the problem is not handled to your satisfaction, then write to the following address:

Digital Watchdog, Inc.
ATTN: RMA Department
5436 W. Crenshaw Street
Tampa, FL 33634

Service calls which do not involve defective materials or workmanship as determined by the Warrantor, in its sole discretion, are not covered. Costs of such service calls are the responsibility of the purchaser.

SPECIFICATIONS*

VIDEO	
Image Sensor	1/2.8" CMOS Sensor
Total Pixels	2000 (H) x 1241 (V)
Synchronization	Internal
Horizontal Resolution	2.1 Megapixels (1920 x 1080) at 30fps
Minimum Illumination	F1.6 (30IRE): 0.10 Lux [Color] F1.6 (30IRE): 0.01 Lux [B&W]
S/N Ratio	50dB (AGC off)
Video Output	HD-SDI, CVBS Analog
LENS	
Focal Length	3.5-16mm
Lens Type	Auto Focus
OPERATIONAL	
Brightness	0-20
Shutter	AUTO / MANUAL
Digital Slow Shutter	OFF / X2 / X3 / X4
Auto Gain Control	0-20
Lens Type	MANUAL / DC / AF
Lens Mde	OUTDOOR/ INDOOR FLK/ DEBLUR120/ DEBLUR240
Auto White Balance	AUTO / AUTO_H / AUTO_I / PRESET / MANUAL / AUTO_EXT
Privacy Zones	OFF / ON (30 Programmable Zones)

SPECIFICATIONS*

OPERATIONAL	
Digital Noise Reduction	OFF / LOW / MIDDLE / HIGH
Digital zoom	1~112
Chroma	0-20
Sharpness	0-10
Mirror & Flip	OFF / ON
Highlight Mask	OFF / ON
WDR / BLC	OFF / WDR / BLC
Language	ENGLISH / CHINESE / GERMAN
ENVIRONMENTAL	
Operating Temperature	-10°C ~ 50°C (14°F ~ 122°F)
Operating Humidity	Less than 90% (Non-Condensing)
Storage Temperature	-20°C ~ 70°C (-4°F ~ 158°F)
ELECTRICAL	
Power Requirement	DC12V Only (10V ~ 16V)
Power Consumption	2.0W, 166.7mA
MECHANICAL	
Housing Material	Plastic
Dome Cover Material	Polycarbonate
Dimensions	∅108 X 96.8 mm (∅4.25 X 3.8 in)
Weight	0.507 lbs

*Specification is subject to change without prior notice.



5436 W Crenshaw St. Tampa, FL 33634
Tel : 866-446-3595 / 813-888-9555
Fax : 813-888-9262
www.Digital-Watchdog.com
technicalsupport@dwcc.tv
Technical Support Hours : Monday-Friday
8:30am to 8:00pm EST